

The Swift Solo, its class rules and constitution, were developed with the intent of accomplishing the following outcomes:

1. To develop a fast and tactical single-handed skiff class that measures sailors' athletic and mental skills in approximately equal proportion.
2. To establish a sailing fraternity that places a high premium on camaraderie and international friendships.
3. To produce boats that are cost effective and remain competitive, at the top level, for 10 years or more. This should be achieved through the prescription of high quality construction methods and materials.
4. To promote class growth while avoiding the pitfalls such as Olympic class status, equalization schemes, and one design rules that extend beyond the purpose of defining the class and keeping long term costs in check. Specifically, the intent is that these rules should facilitate easy installation (modification and movement) of running rigging and other equipment appendages, while the design components that define and characterize the class –hull shape, mast, bow pole and maximum sail dimensions will be tightly controlled. The Swift Solo, therefore, is not an open development class. However, implementation of rules should never be used to block or completely restrict innovation in the class in an effort to attract larger numbers.
5. To become a class that is controlled by boat owners in the tradition of the International 505 class.

RULES of the INTERNATIONAL SWIFT SOLO CLASS 2003 Edition

PREFACE

The Swift Solo skiff is a 4.41m long single-handed skiff.

Originally designed as a single handed trainer for International 49er sailing, the Swift Solo has proven itself to be the fastest, easy to handle, single-handed skiff.

The essence of the Class is it's rules and practices and these are outlined in this book.

TABLE OF CONTENTS

Part A INTERNATIONAL SWIFT SOLO ASSOCIATION CONSTITUTION

1. General
2. Membership and Dues
3. Management
4. National Class Associations
5. Swift Solo Championships

6. Other Official ISSA Championships
7. Amendments

**Part B RULES AND INTERPRETATIONS FOR THE CONTROL OF SWIFT
 SOLO CLASS BOATS**

1. General
 - 1.1 Purpose of the Measurement Rules
 - 1.2 Authority
 - 1.3 Eligibility
 - 1.4 Class Rules and their Interpretations
 - 1.5 Measurement and Measurers
 - 1.6 Owner's Responsibilities
2. Administration
 - 2.1 Language
 - 2.2 Administration of the Swift Solo Class
 - 2.3 ISAF Plaque
 - 2.4 Builders
 - 2.5 Registration
3. Protection of one-design
4. Construction and measurement rules
 - 4.1 Identification Sticker
 - 4.2 Hull and Deck
 - 4.3 Daggerboard
 - 4.4 Rudder
 - 4.5 Weight
 - 4.6 Mast
 - 4.7 Boom
 - 4.8 Sail
 - 4.9 Equipment
5. Special regulations

Part C INTERNATIONAL SWIFT SOLO CLASS MAJOR CHAMPIONSHIP RULES

Part D ENTRY SYSTEM FOR ISSA OFFICIAL CHAMPIONSHIPS

Part E DUTIES AND RIGHTS OF ISSA EXECUTIVE OFFICERS

Part F MEASUREMENT CERTIFICATE (fold-out)

Part A

INTERNATIONAL SWIFT SOLO ASSOCIATION CONSTITUTION

1. GENERAL

- 1.1 The Swift Solo ("the boat") is a one design skiff designed by Bram Dally. The Administering authority shall be called the International Swift Solo Association (ISSA).
- 1.2 The emblem of the Class shall be a black Swift motif, as prescribed in measurement Rule 4.8.4.1.
- 1.3 The object of ISSA shall be:
 - To promote class development and racing throughout the world under uniform rules.

- To maintain control of the character, the design, and registration of Swift Solos.
- To co-ordinate the activities of National Swift Solo Class Associations.
- To promote and maintain friendship between members
- To maintain close co-operation with National Authorities, National Swift Solo Associations and the International Sailing Federation (ISAF).

2. MEMBERSHIP

- 2.1.1 Membership of the ISSA shall be open to anyone interested in Swift Solo sailing upon payment of dues fixed by the Council.
- Privileges of an ordinary Member are:**
- 2.1.2 to be a Member of his or her National Association;
- 2.1.3 to hold any office and to attend International and National General Meetings;
- 2.1.4 to act as a helmsman in any race.
- 2.2 A Member who is an owner or part owner of a registered Swift Solo shall be a "Boat-owning Member".
- Privileges, in addition to those of an ordinary Member are:**
- 2.2.1 to be a Member of a fleet within the jurisdiction of the National Association of the country in which he resides.
- 2.2.2 to vote on all matters, except that part owners of a boat may not cast more than one vote between them per boat on matters affecting this Constitution or the Measurement Rules.
- 2.2.3 The Council may award Honorary Life Membership to Swift Solo sailors of particular distinction.
- 2.3 Application shall be made in writing to the Secretary of the proposed member's National Association (or to the International Secretary if s/he has none) and such application shall state name, address, and qualification for Membership, including the sail number of his boat, if applying for Boat owning Membership. The Secretary shall grant the application for Membership subject to ratification by the next meeting of the National Committee (or International Executive Committee ("IEC")). The appropriate Committee has absolute discretion to ratify or revoke the grant of Membership. Membership dues shall be revised by the Council from time to time. Membership dues shall be paid through National Class Associations to ISSA by May 1st in each calendar year. No rights or privileges of membership shall be enjoyed by anyone after that date whilst his dues remain unpaid. If the payment is received after the deadline date, an additional fee of 25% of the dues may be charged.
- 2.4 The minimum number of dues per National Class Association is 5 per year.

3. MANAGEMENT

- 3.1 The Members of ISSA delegate general jurisdiction and control over all proper Swift Solo Class activities to the Council of ISSA (the Council). The Council shall in turn delegate the management of ISSA to the International Executive Committee (IEC).
- 3.2 The Council shall consist of the representatives (properly appointed in writing) of each National Class Association and the Executive Officers.
- 3.3 Each National Class Association representative shall have one vote plus one extra vote for every 10 paid-up memberships; 10 memberships gives 2 votes, with a maximum of 5 votes. Executive Officers shall have one vote each, unless they are also National Class Association Representatives, in which event they shall vote as such.
- 3.4 An Annual General Meeting of the Council shall be held during the major Swift Solo Gold Championship Week at the time and place to be fixed by the President, who shall circulate to members of the Council, at least one month before the Meeting, an Agenda which must include imperatively:
- The Treasurer's statement of the National Class Association representatives' voting powers, based on the ISSA dues received.
 - Approval of the Minutes of the last AGM.
 - Reports of the Executive Committee members and of each Subcommittee.
 - Approval of the Summary of the Accounts of the previous year and of a Budget for the next year.
 - Election of the members of the Executive Committee, Technical and other Committees, ISSA Measurers, ISSA Advisors, ISSA Delegates to the ISAF November Meeting when ISAF acceptance becomes available, and the ISSA Liaison Officer to the ISAF.
 - Approval of venues and dates of ISSA Championships.
 - Any item presented to the President in writing at least two calendar months before the Meeting.

The AGM may, by a simple majority, decide whether any other business should be added to the Agenda.

The Council has the sole right to approve increased national quotas for entry to ISSA championships as allowed in exceptional circumstances (see Part D).

- 3.5 There shall be the following Executive Officers:
- President
 - Vice-President
 - Treasurer
 - Chairman of the Technical Committee

who shall form the "International Executive Committee". The Executive Officers for each year, shall be elected by the Council at its Annual General Meeting and nomination for the appointments of the Executive Officers shall be notified in writing to the President two months prior to the Annual General Meeting. The Executive Committee is responsible for implementing the policy of the Council as expressed at its AGM, and is responsible to the Council.

- 3.6 The Executive Officers' term of office shall take effect immediately upon election. Executive officers may be re-elected to serve multiple terms.
- 3.7 The Executive Committee shall be empowered to designate the country in which the funds will be kept for the ensuing year.
- 3.8 A Technical Committee shall be responsible for control and enforcement of the Measurement Rule and design of the Class in general. There shall be no limitation as to the number of members of the Technical Committee. Its members shall be elected each year by the Council at its Annual General Meeting.
- 3.9 Interpretation of the Class Rules shall be proposed by the Technical Committee to the Council, or when an immediate interpretation is required at ISSA events, to the Executive Committee. This interpretation shall be ratified or altered by the Council or the Executive Committee and thereafter submitted to the ISAF for final decision at its next meeting.
- 3.10 The Executive Committee shall appoint a Finance and Marketing Committee, consisting of the President, the Treasurer, and not more than three others, who shall act in an advisory capacity to the Executive Committee on ISSA finances, advertising and the production of SWIFT SOLO FARE.

4. NATIONAL CLASS ASSOCIATIONS

- 4.1 National Class Associations (NCA's) may be set up to have the jurisdiction over their members and Swift Solo Class activities within their own national boundaries and shall be autonomous.
- 4.2 The Executive Committee may lay down rules for the recognition of NCA's for the purpose of ISSA activities (e.g., for the right to take part in ISSA-sponsored regattas). Such rules, which shall be subject to ratification by the Council, may provide for minimum paid-up membership fees, the payment of royalties, and any other matters considered relevant by the Executive Committee.
- 4.3 NCA's shall be responsible to ISSA for enforcement of the Measurement rules and for promoting the objectives of ISSA within their national boundaries.
- 4.4 NCA's shall be responsible for collecting ISSA dues from their members and for remitting such dues annually to ISSA by the date specified in Section 2.2. NCA's shall be responsible for the issue of sail numbers, Measurement and Registration Certificates, and annual Membership Stickers to their members, also for keeping copies of the Measurement Forms, but may delegate these responsibilities to their National Sailing Authorities. Each NCA shall be responsible for duly appointing its representative to the Council.

5. SWIFT SOLO WORLD CHAMPIONSHIP

- 5.1 Once the class is established, every year one week's racing (not less than four races) will be scheduled for the Swift Solo World Championship. These will be the official World Championship of the Class. Subject to ratification by the Council, the Executive Committee shall lay down rules to apply to the sailing for the Swift Solo World Championship.
- 5.2 In laying down such rules, the Executive Committee shall take into account that it is desirable to organise the event so that the maximum feasible number of Swift Solo sailors from as many countries as possible may be gathered together for the week of racing. Any limitation on the number of entries should also allow proportional representation according to the numbers of members of each individual NCA.

6. OTHER OFFICIAL ISSA CHAMPIONSHIPS

The Executive Committee may arrange other official ISSA championships such as the North American Championship, the European Championship, the Masters World Championship, and the Australian Championship, subject to approval of the Council as specified in Section 3.4. The Executive Committee may lay down rules for the organization of such events.

7. AMENDMENTS

No amendment may be made to this Constitution except by a two-third majority of the Council at its Annual General Meeting.

Part B

RULES AND INTERPRETATIONS FOR THE REGULATION OF THE SWIFT SOLO CLASS BOATS

1. GENERAL

1.1 The Swift Solo is a restricted development class designed by Bram Dally.

1.2 The administering authority is the International Swift Solo Association (ISSA, the International Association) subject to its Constitution and subject to the rules of the ISAF.

1.3 The official language shall be English.

1.4 Amendments to these regulations may be passed and adopted after a postal vote which carries a 2/3rd majority of owners, entitled to vote, who respond by forwarding a completed ballot to the ISSA in favor of the measure.

1.4 Rule Changes or amendments may be submitted to the ISSA by any three owners entitled to vote, not later than the 28th February, in order to be eligible for the Ballot.

1.6 The official measurement system shall be Metric. Figures in brackets are only for convenience. Metric measurements are binding.

1.7 Neither the designer nor the International Association nor the ISAF nor any National Association accepts any legal responsibility in respect of these Regulations or Rules or the designer's drawings or any claims arising from them.

1.8 The object of these Swift Solo Class Rules (the Rules) is to ensure the Swift Solo is:

- a) a restricted design dinghy with significant latitude for rigging and centerboard innovation;
- b) of tactical and substantially uniform performance;
- c) competitive, with the emphasis placed on the skill of the helmsman;
- d) affordable to sailors.

To further these objects, these are the Rules for Swift Solos measured and registered with a regional entity (Local Authority) that is recognized by the International Swift Solo Association.

2. OBLIGATIONS OF OWNERS

2.1 Obligations

In all circumstances, it is the onus of a person who either owns or manages the affairs relating to a Swift Solo (known in these rules as the owner) to ensure it complies with the class restrictions.

2.1 Non-Compliance

A Swift Solo not complying with these Class Rules shall not sail in any race.

If a Swift Solo not complying with the Rules does sail in a race, it shall be disqualified, as required by Rule 8.

3. ADMINISTRATION

3.1 Royalty and Fees

Upon the application for a sail number and registration of a new boat (but prior to completion) the following fees shall be payable:

- a) The designer's royalty which is such sum as the International Association shall decide from time to time, upon recommendations of the IEC, not being less than three hundred US dollars and shall be payable to the designer, either directly or through the International Swift Solo Association (ISSA). This fee must be paid prior to bonding the deck to the hull. Failure to do so will cause irrevocable exclusion of the hull from participation in ISSA events
- b) The ISAF registration fee shall be paid by the builder on every hull built, whether or not it is subsequently measured and registered. Payment shall be made to the ISSA which shall direct payment to ISAF which will issue an ISAF plaque.
- c) The ISSA registration fee, which is such sum as the International Association shall decide from time to time upon the recommendation of the IEC.

The cost of plans shall include the designer's Royalty for one boat and the ISAF and ISSA registration fees. Hull ID and Sail numbers are issued by the International Secretary upon receipt of payment of the designer's royalty and the ISAF registration fee.

3.1.1 **Registration and Measurement certificates.**

Application for measurement and ISSA registration shall be the responsibility of the Owner. An official measurer shall complete the Measurement Form, and, if satisfied, shall certify thereon that the boat complies with the Class Rules. The ISSA will issue official measurement and registration certificates to each boat when the following conditions have been fulfilled:

- a) Measurement form, completed by an official measurer, is produced by the owner and accepted by the ISSA.
- b) The owner produces evidence of payment of royalty, ISAF class and ISSA registration fees, measurement fee, if any, and current ISSA dues, as set down by the ISSA.

3.2 **Change of ownership** invalidates the registration certificate, but re-registration may be effected by returning the old certificate to the ISSA, together with details of new owner and re-registration fee, if any, whereupon a new certificate will be issued.

3.3 **Eligibility.**

A Swift Solo may not sail in an ISSA sanctioned event unless:-

- a) It is registered
- b) It has a valid measurement certificate
- c) It displays the Swift Solo insignia
- d) It displays a registered name and ensign,
- e) It's owner and helmsman are members in good standing of the ISSA.

3.4 A **Measurement Certificate** issued or endorsed by the ISSA shall remain valid so long as the boat continues to comply with these Rules,

3.4.1 The Owner of the boat is responsible for ensuring that the Measurement Certificate is not rendered invalid from any cause.

3.4.2 If any details on the Measurement Form or Measurement Certificate are altered the Owner shall arrange for an Official Measurer to re-measure the altered items.

3.5 **REGISTERED SWIFT SOLOS**

Approved Swift Solos shall comply with the following additional requirements in order to be first registered.

3.5.1 **Hull serial ID number.**

Each registered Swift Solo shall have embossed or otherwise permanently marked in the starboard transom, a hull identification number of the following format.

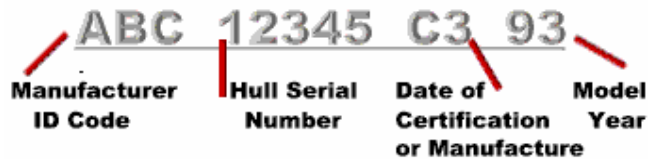

JAN	A	JUL	G
FEB	B	AUG	H
MAR	C	SEP	I
APR	D	OCT	J
MAY	E	NOV	K
JUN	F	DEC	L

3.5.2 The US manufacturer code for the Swift Solo designer shall be WAZ. Coast Guard registered manufacturers may use their code. Non-US Hulls may use their 3 letter Country abbreviation in the ID code Field. The Swift Solo craft is intended solely for racing and may be exempt from CE marking under article 1.3a of directive 94/25/EC of the European Parliament.

4. RULES TO BE FOLLOWED WHEN BUILDING A SWIFT SOLO

4.1 So as not to frustrate the objects of the class, the Rules must be honored when building a Swift Solo.

4.2 The hull must be constructed in accordance with the full size frame template drawings available from the Designer or the International Swift Solo Association. Evidence of proper bulkhead installation shall be required and dated photos of the bulkheads prior to bonding the hull to the deck must be submitted to the class measurer before a valid registration certificate can be issued.

4.3 Scope

The:

- a) hull; and
- b) spars and
- c) sails; and
- d) centerboard; and
- e) rudder; and
- f) rudder housing

of a Swift Solo must comply with the Class Rules.

4.4 Restricted Features and Materials

To ensure the objects of the class are not prejudiced, where a person proposes to build a Swift Solo which:

1. Incorporates a design feature of the hull not expressly specified in the template drawings plans and construction manual; or
2. Proposes to use a material in the construction of a:
 - a. hull; or
 - b. spar or
 - c. sail; or
 - d. centerboard; or
 - e. rudder; or
 - f. rudder housing

not currently in use in Swift Solos already racing, the owner must seek the approval of the Technical Committee of the ISSA before constructing the Swift Solo.

4.5 Advisory Rulings.

Builders intending to construct boats for measurement under these Rules are advised to submit details to the ISSA, or its approved representative, of any feature which may impinge upon the spirit or letter of these rules. Upon submission of full drawings and explanations, a confidential advisory ruling may be obtained without obligation.

4.6 Prohibited Materials.

The Specifications Committee may prohibit the use of any materials in the construction of a:

- b. hull; or
- c. spar or
- d. sail; or
- e. centerboard; or
- f. rudder; or
- g. rudder housing

that, in its opinion, would prejudice the objects of the Rules.

4.7 Boat Identification

4.7.1 The Name

The registered name of the Swift Solo must be placed externally on the transom in no less than 50mm high durable letters. No other writing but the registered name and the Swift Solo's club may be placed on the transom. Writings and logos on other parts of the hull are unrestricted. No two Swift Solos can carry the same name.

4.7.2 The Ensign

To allow for accurate identification of Swift Solos while racing, each Swift Solo must have a distinguishing number and colored design attached to each mainsail it uses. No two Swift Solos shall have the same design. Such a name or ensign design shall measure at least 600mm () in length in any direction. Where, two Swift Solos nominated for a race appear to have ensigns that are similar, the Authority conducting the race may provide a suitable amendment to one of the ensigns.

4.7.3 In the event of a name or ensign conflict the owner who first registered the name or ensign can continue using it, until he advises his Local Association he is relinquishing it.

5 MEASUREMENT RULES

5.1 General

The intention of these rules is to ensure that the boats have as identical a performance as possible. This shall be achieved by consideration of – but not exclusively – hull shape, weight, weight distribution and sail plan. It is impossible to foresee every conceivable innovation which may be thought of in the future. When considering anything in connection with the boat or sails or equipment which is not within established practice in the Class or involves the use of a material not previously used or accepted by the Class or is not clearly covered by the plans, manual, or specification, you must obtain a ruling from the Class Technical Committee before attempting it.

5.2 Measurement tolerances are intended to allow for genuine building errors only and shall not be deliberately used to alter the design. Measurement shall be carried out using these rules in conjunction with the class plans and measurement diagram(s). Should any conflict arise between the written rules and the measurement diagrams, which form part of the rules, then the written rules shall prevail.

5.2 Registration may be granted to a boat which does not comply with the specific requirements of the class rules if in the opinion of the ISSA, the departures are due to genuine building errors only and can only adversely affect the performance of the boat. Any such departures shall be entered on the Registration Certificate.

5.3 Any boat having a Measurement Certificate or any sail bearing a Measurement Stamp dated prior to the priority date of these rules may be measured in accordance with the rules prevailing at the date when the boat or sail was first measured unless these rules state to the contrary or unless the boat or sail has been altered, modified or renewed after the date of any relevant change to these Rules.

5.4 Any restricted equipment which is altered, modified or renewed shall conform to the current rules.

5.5 Boats and their equipment shall be measured only by measurers appointed by the International Technical Committee ("ITC") in consultation with the ISSA Executive committee (IEC) or appointed by ISAF.

5.6 No owner may officially measure his own boat, sails or equipment, nor may a builder or sail maker measure his own products.

5.7 Measurement shall be carried out using only the documents supplied by the ISSA, namely these rules, measurement diagrams, appendices, interpretations, and the Measurement Form (including Instructions to Measurers) and the Official Templates.

5.8 Any templates used in measuring hulls shall be made from reproductions of the original full size sections drawing. Such reproductions shall be made by contact process onto stable film (e.g. Mylar) and distributed by the ISSA.

5.9 In addition to the particulars required by the Measurement Form, the Measurer shall report on the Form anything which he considers to be a departure from the intended nature and design of the boat or to be against the general interest of the Class. In these circumstances the Measurement shall be sent to the ISSA EC through the International Secretary. The ISSA EC shall refer the matter to the ITC to recommend whether or not a Measurement Certificate should be granted. The EC is empowered to grant dispensation in exceptional cases. Such dispensation shall be recorded on the Measurement Certificate.

5.10 Re-measurement may be ordered by ISSA, its authorized representative or a National Association, at any time.

5.11 Sails shall be signed, dated and marked by the measurer as described in the relevant rule.

5.12 **Measurement of the Hull**

5.12.1 **Construction**

- a. Boats may be either amateur or professionally built.
- b. The hull shell (not including stringers frames or similar stiffening) may be substantially built only of Western Red Cedar core, S-glass exterior, Kevlar/carbon hybrid interior, and WEST System epoxy. Accent strips of other woods shall be allowed but shall not constitute more than 5% of the surface area.
- c. The thickness of the skin and planking of a hull shall not exceed 10 mm (3/8inches) nor shall it be less than 5.5mm (7/32 inches).
- d. Each panel of the hull shell (i.e. bottom, side, deck) with the exception of transom and side bulkheads, shall be of uniform thickness over entire area. This rule does not apply to reinforcing under frames or other internal structure and is intended to prevent concentration of weight amidships.

5.12.2 **Hull Shape**

- a. The hull must be constructed in accordance with full size frame template drawings available from the ISSA.
- b. The hull shape shall conform to the designer's drawings within the tolerances specified by the Measurement Diagrams and these Rules. Note, Tolerances are provided on hull measurement stations and points to allow for building inaccuracies only. Any attempt to design within the tolerances will not be allowed.
- c. If a measurer believes that a Swift Solo has been built with deliberate variations from the hull full size frame template drawings, the measurer must refuse to fill out a hull measurement form.

5.12.3 **Hull Dimensions**

- a. The aft measurement point (AMP) shall be a point on the centerline which is a continuation of the plane of the deck where it meets the plane of station 14 as described in the plan diagrams. Hull measurements shall be referenced to the AMP. Explanatory Note: The transom is inset from the AMP by 6mm +/- 2mm. The term

transom if referred to as an alias of the AMP shall include the addition of this inset amount.

- b. Length overall shall be measured with the hull's designed waterline horizontal, between perpendiculars at the AMP and the forward most protrusion of the hull. This measurement shall be a minimum of 4.363m (171 3/4 inches) and a maximum of 4.375m (172 1/4 inches).
- c. The beam at the widest point shall be a maximum of 1.934m (76 1/8 inches).
- d. No foot stops or other hull protrusions shall be allowed that increase the width of the hull or the righting moment.
- e. The depth shall be measured at a point 2132 mm (84 inches) from the AMP, from the outside of the planking on the keel to a straight line across the gunwales. At this point depth shall be a minimum of 500 mm (19 11/16 inches) and a maximum of 513 mm (20 3/16 inches).

5.12.4 **Sheerline**

- a. The gunwhale shall be fair and continuous.
- b. The sidestay chainplate centers shall be located not less than 1950mm (76 3/4 inches) nor more than 1.975m (77 3/4 inches) forward of the AMP. In addition, the chainplate centers shall be equal distances from the centerline must be not more than 1435mm (56 1/2 inches) nor less than 1385mm (54 1/2 inches) from each other. The chainplate shall be fastened through to the outside of the hull.
- c. The mast step shall be so located that the aft side of the mast is 2.325m +/- 30mm (91 1/2 +/- 1 3/16 inches) forward of the AMP,

5.12.5 **Centerboard Case**

- a. The centerboard case slot shall be located between 1.803m (71 inches) and 2.185m (86 inches) from the AMP, measured along the keel of the boat, and shall conform to the plan diagrams and shall not be more than 38mm (1 1/2 inches) wide.

5.12.6 **Decking and Buoyancy**

- a. The cockpit and deck design shall conform to the designers drawings.
- b. The height of the cockpit floor shall be 267 mm +/- 6mm (10 1/2 inches) above the keel (outside of planking) measured at the aft end of the centerboard case.
- c. The height of the cockpit floor at the transom shall not be more than 115 mm plus or minus 6mm (4 1/2 inches) above keel (outside of planking) measured on the centerline. Cutouts or steps other than those shown on the drawings shall not be allowed in cockpit floors.
- d. The depth of the deck, at the position of the rear of the mast when stepped, shall be measured from a straight edge on top of the gunwales and shall be 190mm +/- 6mm (7 1/2 +/- 1/4 inches)
- e. The spinnaker throat shall be wholly within two planes perpendicular to the centerline at positions 3.429m (135 inches) and 3.734m (147 inches) forward of the AMP.
- f. A Swift Solo, when capsized; and filled with water shall have sufficient buoyancy to support its crew on the surface of the water.

5.12.7 **Structural integrity.**

- a. It is not practicable to test each boat by complete immersion of the watertight compartment. The measurer shall inspect the compartments carefully and satisfy himself that they are tight. The owner shall maintain the integrity of the watertight

compartment in an efficient condition and the Measurement Certificate will automatically become invalid should he fail to do so.

- b. Internal bulkheads and supports shall conform in shape and reinforcement to the designer's template drawings and specifications. Specifically, internal bulkheads at stations 8 and 6 will be perpendicular to the centerline and properly bonded to the hull and deck structure. Inspection holes will be arranged in the hull and bulkheads as specified in the plans to facilitate inspection by camera of the forward bulkhead and foredeck soldiers.

5.12.8 Alterations to the Hull

- a. A hull's shape cannot be altered after it is registered unless it is re-measured and the re-registration fee, if any, is received by the ISSA.
- b. Sub-rule 512.8.a shall not prevent an owner repairing a hull to fix:
 - i. damage; or
 - ii. ordinary wear and tear.

5.12.9 Weight restrictions

- a. The hull, in dry condition and with no free water in any part, shall weigh not less than 77 kilograms. (170 lbs.).
- b. When being weighed the hull shall include essential fittings,
- c. Essential fittings are defined as:
 - i. Any fittings that are permanently fixed, bolted, glued or screwed to the hull.
 - ii. boomvang system (less vang arms and lever) ; and
 - iii. Cunningham system; and
 - iv. jib car track and pulleys; and
 - v. rudder box, tiller, and
 - vi. jib downhaul system if any;
 - vii. jib sheets (less final sheeting that enters the boom); and
 - viii. mainsheet bridle; and
 - ix. mast step; and
 - x. spinnaker bag; and
 - xi. spinnaker pulleys; and
 - xii. tack line; and
 - xiii. trapeze shock cords, and
 - xiv. spinnaker pole and
 - xv. inspection ports and their covers.

In accordance with ISAF Measurement Instructions, 'fixed' means that a tool is required to remove this item from its position.

- d. When weighing a Swift Solo, these fittings are not to be included:
 - i. spinnaker sheets; and
 - ii. the mainsheet; and
 - iii. Foils and Spars other than the spinnaker pole.
- e. If the hull is found to be underweight, lead corrector weights, without limit, shall be added to the deck closest to the mast. No other inside ballast shall be carried. Neither any essential fixed fittings nor any correctors shall be removed or altered without the boat being re-weighed by an Official Measurer, and the revised weight being recorded on the Measurement Certificate. The weight of any correctors shall be stated on the Measurement Certificate.

5.12.10 Weight distribution and center of gravity

Principles: The object of this rule is to prevent concerted efforts to decrease the hulls mass moment of inertia (MMI) by concentrating structural weight amidships. It is the contention of the class that such activities fall outside the objects of the class because they limit the competitive

half-life of the hull. It is to be noted that much leeway to adjust the pitching moment of the rigged Swift Solo is already allowed by the broad specifications for the mast spar and sails. Accordingly, efforts to redesign the scantlings are illegal. The degree of concentration of the weight in the boat is described by the radius of gyration and shall be measured with the class swing test which is based on the test designed by Gilbert Lamboley.

- a. Hulls when first measured or after a major repair or alteration shall be subject to the swing test in accordance with rule 5.1.
- b. This test must be conducted indoors and/or in a draught-free environment
- c. The arrangement of gunwale, capping or external molding, and/or fittings shall be such that they shall not obstruct the use of the class approved swing test gear. (See drawing). Any fittings or equipment in this area shall be easily removable.
- d. The ISSA shall construct, maintain and distribute data concerning the mean and standard deviation (SD) of class swing test parameters defined in 5.12.10e. The mean shall be based on a quorum of not less than 10 boats which do not require significant addition of corrector weight.
- e. When the hull as defined in sub-rule 5.12.9b is swung from the class approved swing test gear in accordance with the procedures outlined in the hull measurement form and the Instructions to Measurers then:
 - i. The center of the bearing point of the swing test gear CGH ("the horizontal swing center") shall not exceed the reference sample mean +/- the sum of two standard deviations of the mean.
 - ii. The height of the swing axis above the center of gravity (CGV) shall not exceed the reference sample mean +/- two standard deviations above the bottom of the hull.
 - iii. The hull's mass moment of inertia shall not exceed the reference sample mean +/- two standard deviations. (A boat of equal mass with "light ends" has a shorter radius of gyration and consequently a lower MMI).
- f. If the hull is found to be underweight in rule 5.12.9 and or the parameters of the hulls moment of inertia deviate more than permitted, lead corrector weights shall be fixed to the hull so as to bring the weight of the hull, CGH and the MMI to the relevant permitted means (not minimums).
- g. The swing test data and the weight and position of all corrector weights shall be entered on the yacht's measurement certificate and submitted to the ISSA Class Measurer.
- h. Corrector weights, if required, shall be clearly visible and the weight and position from the AMP of each shall be permanently marked thereon.

5.13 Measurement of Rigging, Sails and Spars

5.13.1 Sail Plan

A general description of the rig plan is provided with the designer's plans and specifications. It is the intention of these rules to maintain the sail plan of the Class to substantially the same design, whilst giving owners freedom to arrange the rigging as they wish. However, the rules will allow variation of some of the critical components of the rig design, for example those that regulate the depowering, automatic response or efficiency of the rig (mainly, but not limited to, mast tip flexibility and hydrofoil combination), in order to allow fine tuning and matching of the rig to the agility, ability and weight of the helmsman. It is foreshadowed that such an approach will maximize the range of crew weight, size and ability levels that can compete effectively in the class.

5.13.2 Rigging

- a. A boat may not have facilities for setting more than one mainsail, one headsail and one spinnaker. No changes of sail are permitted during a race or regatta series.

- b. Standing and running rigging arrangements are optional except where specified in these rules.
- c. The class approved forestay fitting measured at the center hole shall be a maximum of 4.223m (166 ¼ inches) and a minimum of 4.210m (165 ¾ inches) from the AMP. The forestay must be attached in the center hole at all times while racing.

5.13.3 Mast Spar

- a. At registration each boat shall have the mast in use indelibly numbered and recorded. Each boat may have two (2) masts registered in any one season. Masts shall be constructed from the following materials: wood, aluminum alloy, glass reinforced epoxy, Kevlar, carbon fiber or any combination. Only one mast and one boom shall be permitted for racing in a regatta. A measurer may approve replacement spars if these are broken.
- b. Excluding fittings, no dimension at right angles to the length shall exceed 75mm (3 inches). The mast diameter below the hounds shall not be smaller than 50 mm (2 inches).
- c. The mast shall have a maximum height of 6.935m (273 inches), which shall be measured from the bottom (or bearing surface) of the heel plug (less the tenon) up the forward face of the mast to the top of the masthead crane.
- d. The mast shall be stepped on deck with the bottom of the mast not more than 32mm (1 ¼ inches) above the deck. The bottom of the mast shall mean the bottom of the mast heel plug excluding the plug's tenon.
- e. The bottom of the mast tenon shall have a maximum height of no more than 6 mm (1/4 inch) above the deck or cockpit floor at the mast step.
- f. A white band 10mm wide shall be placed round the mast at the following two positions measured up the front of the mast with the mast lying straight and perpendicular to the baseline at the bottom of the heel plug as defined in 5.13.3c
 - i. Boom band, Upper edge 832mm (39 inches) above the bottom of the mast heel plug.
 - ii. Head band, Lower edge 6.845m (269 ½ inches) above the bottom of the mast heel plug.
- g. The top of the headboard of the sail shall not be hoisted above the lower edge of the Head band. The top edge of the boom (including track) or its extension shall not, when the sail is set, intersect the aft side of the mast (including track) higher than the top edge of the boom band nor lower than the lower edge of the boom band.
- h. The highest point of entry onto the block, sheave or fairlead for the spinnaker halyard, when at 90degrees to the mast and extended as necessary, shall be not more than 6908 mm (272 inches) above the bottom of the mast heel plug.
- i. No rigidly fixed point for attachment of a block, sheave or fairlead shall be more than 35 mm (1 3/8 inches) from the surface of the mast.
- j. The highest point of attachment for the forestay shall not be more than 4.625m (182 1/8 inches) above the bottom of the mast heel plug and shall not protrude from the mast more than 6 mm. A prolongation of the luff of the headsail when set shall cut the fore-side of the mast at or below this position.
- k. The highest point of attachment for the primary shrouds shall be 4.490m (176 ¾ inches) above the bottom of the mast heel plug.

5.13.4 Spinnaker Pole

- a. The Spinnaker Pole shall be retractable to within 700mm (27 5/8 inches) of the stem. The length from the AMP to the outer most extremity of the spar, when the spar is fully extended shall not exceed 6.095m (240 inches).
- b. The outer end of the spar shall be solid or capped to avoid a sharp edge.
- c. The maximum cross sectional depth of the pole shall be 72mm. The spinnaker pole shall not be used as a bowsprit for headsails or when sailing close hauled.

5.13.5 **Boom**

- a. Booms shall be of any design except that:
 - i. The maximum dimension of any section perpendicular to the longitudinal axis shall not exceed 100mm (3 15/16 inches) ...
- b. Booms shall be constructed only from the following materials: wood, aluminum alloy, glass, Kevlar or carbon fiber reinforced epoxy or any combination.
- c. A band of contrasting color not less than 10mm (3/8 inch) wide shall be placed round the boom with its inner edge not more than 2.290m (90 1/8 inches) from the aft face of the mast when the boom is in sailing position.
- d. The overall length of boom from the mast intersection point to the outer end of boom shall not exceed 2.340m (92 1/8 inches).

5.13.6 **Centerboards and rudders.**

- a. Only one centerboard and one rudder shall be permitted in a contest. A measurer may approve replacement centerboards/rudders if these are broken
- b. The rudder and centerboard shall each consist of single vertical foils. They shall not be ballasted and shall float.
- c. The centerboard may be of any construction or plan and sectional shape, provided that it does not exceed the maximum plan profile shown in the full size measurement diagrams or the dimensions given in Appendix A and Instructions to measurers.
- d. Maximum width of centerboard, perpendicular to the chord and longitudinal axes, is 36mm (1 3/8 inches)
- e. The rudder shall match the profile and section defined by these class rules.
 - i. The official rudder foil of the International 49er class shall be acceptable.
 - ii. Alternatively, rudders may be built to comply with the section and profile designated by ISSA.
 - iii. Rudders built to tolerances that fall between the official ISSA sections and profiles and those of the official 49er rudder shall be acceptable.
- f. No appendages shall be allowed below the waterline on the
 - i. centerboard or
 - ii. rudder
- g. The centerboard may be shaped or fitted with any device by which it will adjust itself or may be adjusted or pivoted about its longitudinal axis while racing.

5.13.7 **Sails**

- a. Sail construction and material are not restricted except that to maintain a low cost of the sails the ISSA may appoint exclusive rights to manufacture approved Swift Solo sails. In

the event of such an exclusive appointment only sails provided by the class approved manufacturer may be used in

- i. National or International competitions.
- ii. Swift Solo Grands Prix

- b. When sails are otherwise regulated by an organizing authority, notice shall be published in the Official Notice of Regatta.
- c. All sails shall be capable of being lowered when the boat is underway. This shall be tested prior to registration of the sail.
- d. Sails registered under these rules may qualify as such until November 1, 2007

5.13.8 **Sail Measurement Procedures.**

- a. The sails are to be measured in a dry condition in accordance with the ISAF Equipment Rules of Sailing and the Class rules, with reference to Diagrams, measurements and instructions on sail measurement in the Appendix: Instructions to Measurers.
- b. The class restrictions shall take precedence where there is any conflict.
- c. The Measurer, if satisfied, shall date and sign the tacks of each sail on the port side and mark the area of the sail in accordance with Rule 14(a).
- d. Sails may be made only from materials approved by the ISSA. Double-surface or inflatable sails are prohibited.
- e. A maximum of 3 sails may be carried while racing
- f. A maximum of 6 sails may be registered per hull at any one time.

15.13.9 **Mainsail:**

The head, clew and tack of the sail shall be defined as a point of intersection of two fair curves extended from the adjacent outside edges of the sail, including the bolt rope if any.

Restricted dimensions of the mainsail are as follows:

- a. **Area:** The total area of the mainsail shall not exceed 9.56 square meters (103 square feet). The mainsail area shall be calculated to include the forward most extent of the sail including the bolt rope, if any, but excluding any fairing sleeve as defined in 15.13.9e. Sail area shall be determined by dividing the sail into triangular facets and using the calculation methods described in the Instructions to measurers to ascertain the sails area. Measurers may apply as many facets as required until satisfied that the sail area has been adequately described.
- b. **Leech:** The leech shall not exceed 5.665m (18ft 7inches) when laid flat stretched free of wrinkles. The length of the leech may be taken as the straight distance between the head and the clew.
- c. **Head Board:** Maximum dimension of the headboard inclusive of the luff rope. at 90 degrees to the luff is 120mm (4 ¾ inches).
- d. Exclusive of fairing sleeves no part of the mainsail when set may extend below the top surface of the boom.
- e. The Mainsail may incorporate a fairing sleeve that extends around the mast. The sleeve may extend from the deck to the attachment point of the lower shrouds.
- f. **Battens:** Battens in the mainsail shall not exceed six in number and the width, inside the pockets, shall not exceed 45mm (1 ¾ inches). Length and position of the battens

are optional. Except that no part of the uppermost batten pocket shall extend above the measurement line defined by subrule 15.13.3f.ii

- g. Distinguishing Marks: On each side of the mainsail shall be the Swift Solo insignia as defined by the measurement diagrams in appendix to these rules. Beneath this shall be displayed the national letters and the class number of the boat as stated on the Measurement and Registration Certificates. The figures shall be not less than 300mm in height and shall be disposed in accordance with RRS 77. Each mainsail shall carry a distinguishing ensign or design in observance of class rule 4.7.2.

5.13.10 Jib.

- a. The jib shall not be lowered or furled while racing. Head tack and clew of the sail shall be defined as in rule 15.13.9
- b. Headboards are not permitted.
- c. Clewboards having a maximum dimension of 100mm (4 inches) are permitted. Clew boards are defined as being incapable of being folded by hand.
- d. Where clewboards are fitted the measurements shall be taken from the point of intersection of the projections of the adjacent edges of the foot and leech.
- e. Registered Jib sails shall conform to the following measurements
 - i. **Luff:** maximum dimension 4.318m (14ft 2 inches).
 - ii. **Leech:** maximum dimension 4.000m (13ft 1½ inches).
 - iii. **Foot:** maximum dimension 1.740m (68 ½ inches).
 - iv. **Leech Roach:** maximum dimension 152mm (6inches). This dimension shall be measured from the point on the leech furthest from the straight line extending from the clew to the head.
 - v. **Foot Roach.** maximum dimension 76mm (3inches). This dimension shall be measured from the point on the foot furthest from the straight line extending from the clew to the tack.
 - vi. Excluding Jib hanks, no part of the Jib when set, may extend forward of the forestay.
- f. Battens: Battens shall not exceed four in number or 45mm in width inside the pockets.

5.13.11 Asymmetric Spinnaker:

- a. Asymmetric spinnakers shall only be set from a spinnaker pole.
- b. One spinnaker only, may be carried on board in any race.
- c. Not more than two spinnakers shall be added to a boat's Measurement Certificate in any 12 month period.
- d. All spinnakers shall be numbered chronologically, dated and signed by a measurer near the tack in a contrasting indelible ink, and those details entered on the Measurement Certificate to facilitate Subrule 5.13.10c.
- e. Luff, leech, foot and girth measurements shall be made with the sail in a dry condition, laid flat, smoothed and pulled taut along the relevant edge tape so that the body material is free of wrinkles along the path to be measured. Luff tensioners, if any, shall be released.
- f. Registered asymmetric spinnaker sails shall conform to the following measurements
 - i. **Luff:** maximum dimension 8.103m (26ft 7inches).
 - ii. **Leech:** maximum dimension 6.147m (20ft 2inches).
 - iii. **Foot:** maximum dimension 3.937m (12ft 11inches).

- iv. **Foot Roach:** maximum dimension 318mm (12 ½ inches). This dimension shall be measured from the point on the leech furthest from the straight line extending from the clew to the tack.
- i. **Half Girth measurement.** The half girth measurement shall be defined as the length from the edge of leech to the edge of the luff along the girth line defined by folding the sail in half by positioning the head of the sail to meet the clew. The half girth measurement shall not exceed 4.065m. (13ft 4inches)

6 **Equipment**

6.1 **Devices** which indicate remotely or receive or correlate data about wind direction, wind speed, boat speed or location shall be prohibited except when required and provided by race organizers.

6.2 **A competitor's clothing** and equipment (IRS 43.1) shall not weigh more than 10 kilograms, excluding a hiking or trapeze harness and clothing (including footwear) worn only below the knee. In all other respects, the provisions of RRS 43 shall apply

6.3 **The trapeze harness** when wet, must float and shall not weigh more than 4kg.

7 **Miscellaneous**

7.1 Any item which a measurer considers may not be in compliance with the Class Restrictions or Objects of the Class Restrictions shall be considered prohibited until a ruling is obtained from the Owners Association.

7.2 **THE FOLLOWING ARE NOT PERMITTED:**

- i. Ballast of any form other than weight correctors.
- ii. Weight belts or clothing to increase the crews weight
- iii. Outriggers, excluding the bow pole, for sheeting sails or any other purpose.
- iv. Any contrivance other than trapeze extending outboard to support the crew.
- v. Spinnaker sheet catchers on the stem which may be dangerous to other craft.
- vi. Appendages: Hydrofoils, sponsons, hull bumping or other devices designed to lift and/or hold the hull above the water.
- vii. Resin systems requiring a curing temperature in excess of 80°C are specifically prohibited for use in hull and deck construction.
- viii. The use of hydraulics is prohibited.
- ix. Rigging arrangements which allow the angle of the bowsprit to be altered while sailing.
- x. Titanium, and titanium alloys are excluded from use in sails, rigging, spars or hull.

7.3 A Swift Solo crew must consist of one person.

7.4 A crew member must be a member of the ISSA in good standing.

7.5 **Lost or destroyed gear**

a. During a Swift Solo Championship series, an owner of a Swift Solo may apply to the Measurer or the Race Committee to register a piece of equipment to replace that which has been destroyed, damaged or lost.

b. During a Swift Solo Championship series when measuring a replacement sail, a measurer is to disregard small variations from the dimensions of the previously measured sail. Where a measurer thinks the replacement sail has been submitted in an attempt to register a sail having a greater performance capacity than the previously measured sail, the measurer must refuse to measure and register the sail

7.6 These Rules are effective from the 1st December, 2003 and shall apply to all boats first measured as a Swift Solo on or after that date. Commercial Builder registrations obtained under these rules are valid until 1st January 2007.

8 **PENALTY FOR BREACHING ANY OF THE RULES**

A Swift Solo sailing in any race found breaching any of these rules must be disqualified.

9 DEFINITIONS:

9.1 The head of the mainsail is defined as the point on the Luff, or its extension, level with the highest point of the sail projected perpendicular to the Luff or its extension.

9.2 Chine: The junction between bottom and topsides outside skin.

9.3 Sheer: Point where the outside surface of topsides or projection thereof meets or intersects the upper surface of the decks.

9.4 Concave: Curved inwards or downwards (hollow). Convex: Curved outwards or upwards.
Camber: As convex

9.5 Gunwale Assembly: The whole of the gunwale construction inclusive of the inside and/or outside gunwales, beltings, cappings etc.

Skin: The shell of the hull excluding structural members to or by which it is jointed.

NOTE: All measurements of weight to be in kilograms to one decimal place only.

(c) International Swift Solo Association, 2003

International Swift Solo Class Rules

APPENDICES

Appendix 1 - Amendments

Appendix 2 - Interpretations

Appendix 3- Instructions to Measurers

Appendix 4- Swing Test

Appendix 5 - Hull Measuring Form

Appendix 6 - Sail Measurers Certificate --- Jib

Appendix 7 - Sail Measurers Certificate --- Mainsail

Appendix 8- Sail Measurers Certificate --- Asymmetric Spinnaker

1 AMENDMENTS

No Amendments.

Last Updated 11/29/03

(c) International Swift Solo Association, 2003

2 Interpretations

1 Changes to the rules.

These Class Rules may be changed after a postal vote by owners of registered boats. A 2/3rd majority of the owners entitled to vote, who respond by forwarding a completed ballot to the ISSA must be in favor, for the measure to be passed and adopted.

Rule Changes or amendments may be submitted to the ISSA by three owners, entitled to vote, not later than the 28th February in order to be eligible for the Ballot. The proposed amendments will be promptly published by the ISSA secretary in appropriate news letters and the class web sites. The ISSA Technical Officer or chief measurer and all ISSA delegate Technical Officers shall be advised promptly of the content of the amendments(s) and will be directed to send to the ISSA not later than the 30th April, a written report setting out their opinion of the proposed amendment(s) The ISSA shall, before 31st May, conduct a postal ballot or direct each National Authority to conduct a postal ballot of the voting members on the amendment(s) and shall make available all reports on the amendments received from the Technical Officers. All voting owners shall be entitled to a copy of the reports from their National Authority. Votes not returned by the National Authority to the ISSA by the 31st July shall be invalid. All votes shall be assessed collectively and the amendment(s) if passed shall become effective at 1st September unless otherwise stated. Amendments shall be applicable to all boats, sails, spars, foils, etc. measured after the date at which the amendment becomes effective. Each National Technical Officer shall determine if boats partly complete on the date when an amendment becomes effective shall be required to conform to the amended rules. Amendment(s) from boat owners may only be considered for voting every third year while the International Technical Officer may submit his own amendments for voting annually.

2 Measurers and the specification committee

a) Measurers

Each recognized local authority must appoint one or more measurers to measure Swift Solos as set out in the Rules.

b) Technical Committee

The Executive Committee of the International Swift Solo Association must from time to time appoint a group to form the Technical Committee. The Executive Committee must appoint one of the people appointed to the Technical Committee to act as the Committee's chairman. The decisions made by the Technical Committee shall be final and binding.

3 Hydrofoils:

The sectional shape of the centerboard hydrofoil may not be uniform from top to bottom. An appendage on a hydrofoil, either rudder or centerboard, shall be defined as a protrusion from the vertical plane that cannot be shipped completely through the rudder box or centerboard case respectively while underway.

4 Example of the operation of subrules 4.4 and 4.5: Restricted Features Materials and Advisory Rulings.

The Specifications Committee has been asked to consider whether a new material can be used in the construction of a hull. If the Committee thought: the performance qualities of the material were so advanced the proposed Swift Solo would outperform other Swift Solos in the fleet, thus defeating the object of having a class possessing substantially uniform performance; or the material cost so much only a few people could afford to use it, it would be open to the Committee to refuse the proposal.

The recommended practice for seeking approval should be followed because if a person fails to seek the approvals required before building the Swift Solo, and then presents a Swift Solo that breaches the conditions set out in paragraph 4.4.1, 4.4.2 or 4.5 it won't be able to be either measured or registered. A lot of effort and expense will thus be wasted. It is the intention of the Rules for relevant approvals to be granted prior to the construction of a Swift Solo.

Advisory rulings are given in writing and in confidence and are not divulged by the ISSA to class members at large, other than relevant class officials and the applicant.

Example of the operation of subrule 4.4: Interpretation EXAMPLE: A hull that fits the maximum template size snugly next to the keel, and then cross over to the minimum template size around the waterline. Such characteristics and visa versa are signs of attempts to design within the builder's tolerance. In these cases the measurer must check additional hull stations and refuse a measurement certificate if similar trends are apparent elsewhere on the hull.

3 Instructions to Measurers.

1 Measuring Forms Hull: A measurer is to use the Hull measurement form contained in the appendix to record relevant measurements

2 The Measurement Method

The hull shall be measured in a measuring jig as shown in the measuring jig diagram. The whole jig is to be set up so that its shape corresponds with the designed shape plus the maximum tolerance all over. Templates will be marked with maximum and minimum tolerance positions of the sheer. (The sheer is the point where the top of the deck and the outside of the side meet). Templates shall be attached to the jig and shaped as shown in the measuring jig diagram so as to allow them to shift sideways and rotate in their vertical plane to allow for any horizontal bend or twist that the hull may have.

3 The hull shall be measured by placing it in the jig and checking that it does not depart from the templates more than the tolerance and that the sheer lies between the maximum and minimum position. The sheer should be a fair continuous line.

The hull tolerance with the exception of the transom shall be plus or minus 6mm and the vertical sheer position tolerance shall be plus or minus 6mm. With the exception of the designed bearing points the hull must not touch the template nor be more than 12mm away.

3. Deck and Cockpit Measurement

When the hull is being measured, station positions shall be marked on the sheer and the shape of the deck and cockpit checked using templates according to the measurement diagrams..

Tolerance to be plus or minus 6mm.

The cockpit shape need not be measured at station 2 or 4. The measurer shall satisfy himself that the cockpit at stations 2 and 4 approximates the design shape.

Swift Solos are to be measured at the following five transverse sections and along the centerline:

- the stem; and
- station 2
- station 6
- station 10
- station 14.

4 Swing Test

WEIGHT DISTRIBUTION MEASUREMENT DIAGRAM

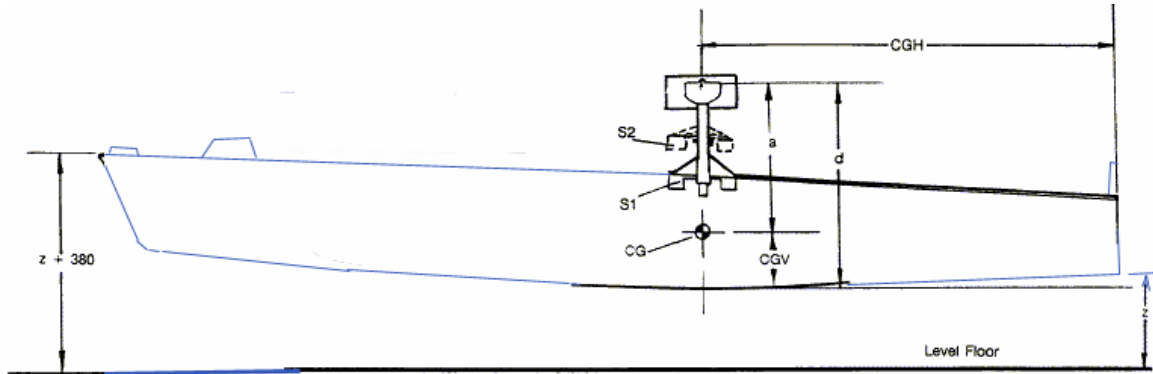

A 90 degree knife edge for the support beam pivot axis is recommended

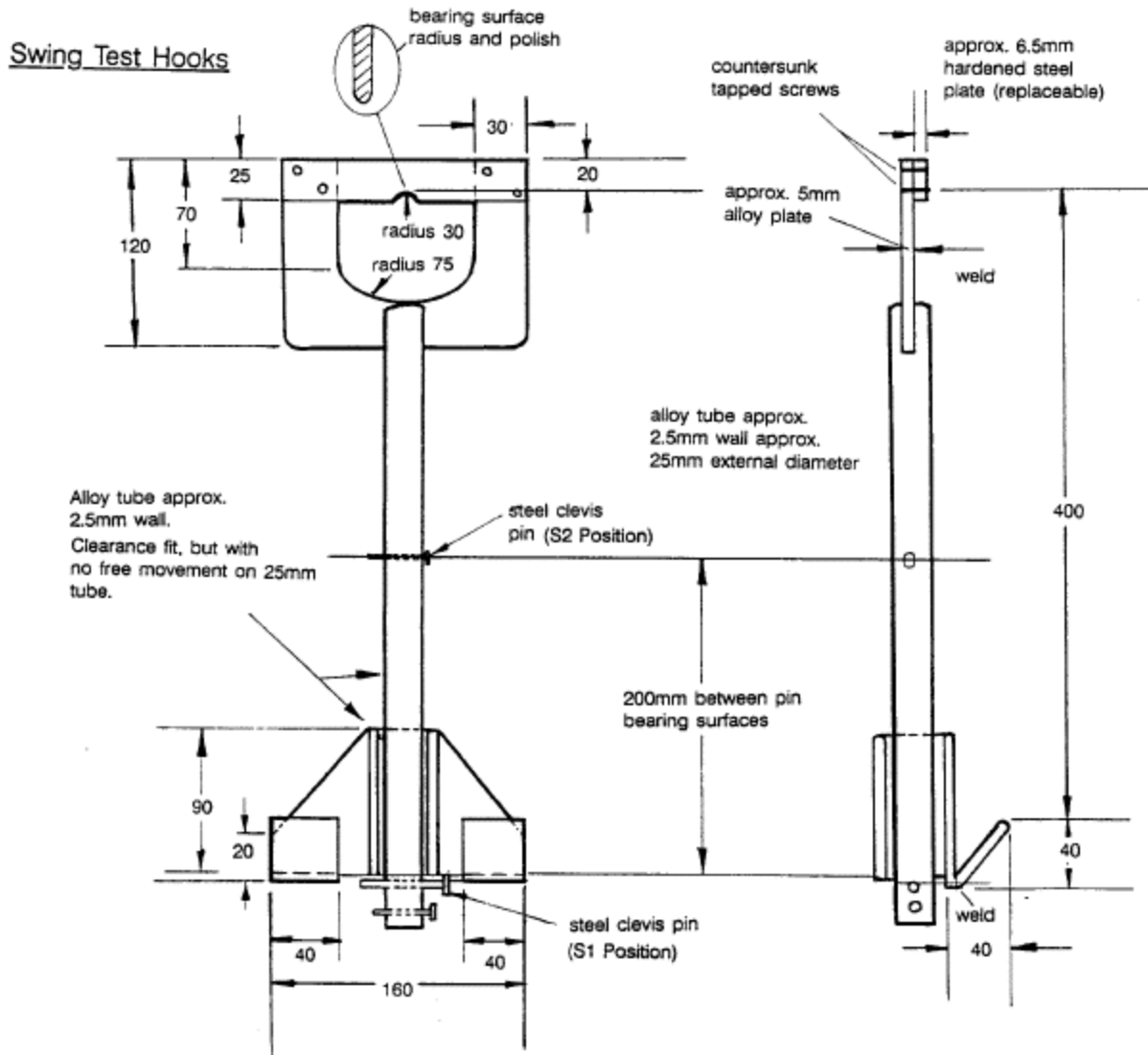

1. The procedure for the swing test is based on the 'Lamboley Test'

The hull is suspended from brackets hanging from a transverse beam which forms the swing axis. The brackets locate on the hull below the rubbing strake. The bracket design allows the hull to be supported at 2 different heights relative to the swing axis. The swing period is measured at each height.

2. The swing period may be measured using either:
 - (i) A stop watch with 1/100 second readout.
 - (ii) An electro-optical device, such as a photo-electric cell linked to an electronic timer or micro-computer. These notes assume the manual, stopwatch method is used.
3. If the weight of the hull is not known, weigh the hull in conditions as defined in rule 5.12.9. Record as 'M' kg.
4. Suspend the hull, supported on the brackets in position S1 as shown in the diagram, so that it is level fore and aft in condition as for weighing. Ensure that the suspension axis is at right angles to the fore and aft line of the hull. When it is, the distance from the aft end of each bracket to the transom will be the same. Mark the bracket position on the hull.
5. Measure:
 - (i) the horizontal distance from the vertical plane through the pivot point of the transverse beam and the transom. Record as 'CGH'.
 - (ii) the height of the support axis above the underside of the hull. Record as 'd'.
6. Set up a support post for a reference pointer close to the bow. Ensure it is just clear of the hull when the hull is swung.
7. Mark a level datum on the reference post aligned to a clearly defined mark or feature on the hull, eg the underside of the rubbing strake. Mark a swing start point on the post 50mm below the level datum.
8. Depress the bow to the start position and release. Allow at least 1 complete cycle for the system to settle.
9. Start the stopwatch as the bow passes the level reference. Count and time not less than 10 complete cycles. Record as 'TTI'.
10. Calculate the mean period for the number of cycles completed, eg record mean period as 'T1'.
11. Repeat steps 6 to 9 with the hull suspended on the brackets in position S2. It is important that the brackets are set at the same fore and aft position on the hull as for S1, using the marks made in the procedure of paragraph 4. Record mean period as 'T2'.
12. Calculations:
 - (i) Calculate the height of the swing axis (a) above the centre of gravity [CG] and radius of gyration [RG] by:
 solving the following equations:

$$a = \frac{0.2 \times b \times T2^2 + 0.04}{b \times (T2^2 - T1^2) + 0.4} \quad RG = \sqrt{(b \times T1^2 \times a) - a^2} \quad \text{where } g = 9.815$$

$$PI = 3.142$$

$$b = \frac{g}{4 \times PI^2}$$

$$= 0.2486$$
 - (ii) Calculate the Mass Moment of Inertia (I) as follows:
 $I = M \times RG^2$ where: M is the mass of the hull
 - (iii) Calculate the height of CG above the underside of the hull (CGV) as follows:
 $CGV = (d - a) \times 1000\text{mm}$
13. Record data on the measurement form.

Notes: WEIGHT DISTRIBUTION AND CENTRE OF GRAVITY: PRACTICE

The brackets are designed to keep distance "a" short, to aid accuracy. The distance S1 and S2 shall be correct to within 1 mm.

It is essential that the measurements be made in a sheltered place. The boat shall be hung from the brackets on axis S1, S2 and the periods of oscillation T1 T2 measured.

The distance "CGH" is measured parallel to base line from AMP to axis S1 (diagram 1). If "CGH" is found close to limit values make sure that base line is level as in diagram 1. The distance "d" can usually be measured from axis S1 to the underneath of the hull (excluding keel band) by means of a rule or tape passed down through the centerboard slot. It is wise to provide a protection under the boat but the boat shall not touch anything while

oscillating. The oscillations shall be small, but should not become damped in less than about 100 periods. There shall be no twisting oscillations about a vertical axis. There shall be NO movement of the supports. The measurement of periods T1 and T2 requires most care. It is recommended to operate in the following way: two time keepers stand on either side of the boat, they shall start their stopwatches when the boat passes the rest position which is made easier with two rods placed opposite each other; they count ten pitching periods and if they get the same result within 0.1s, the measurement is satisfactory. Stopwatches accurate to 0.05s shall be used. If a stopwatch only accurate to 0.1s is used, twenty pitching periods shall be measured.

If a correction is necessary, record the results obtained after correction and the amount and position of the corrector weights.

4 Recording the Sail Measurements

Measurements shall be entered and calculations made on the relevant sail measurement forms as contained in the appropriate appendix, together with the name of the Swift Solo, owner's name address and contact information, description of sail, its serial number and date. This form is to be transmitted to the ISSA secretary and a copy retained by the Swift Solo's owner and the Boat and Sail Measurer.

The sail should be held with spikes and a string line placed around the spikes that intersect the sails corners or extensions thereof and measured. All measurements shall be to the nearest 5 mm.

The luff may be tensioned so as to remove wrinkles and then the corner fixed, then the leech and foot pulled so as to just remove waves or wrinkles from the sail's edges.

All rounds or hollows will be measured to the point of maximum width or depth.

Jib The sail will be laid down on a flat surface and smoothed from the centre out to attempt to flatten the sail while keeping the luff, leech and foot from wrinkling.

All control lines shall be made loose. The distance between girth measurement points and the extensions of the head to clew, clew to tack and tack to head shall be recorded in meters to the nearest 5 mm ().

Last Updated 11/29/03

(c) International Swift Solo Association, 2003